



AMATEUR RADIO FD★26

A NATIONAL RESOURCE

1

RST Field Day Planning June 27-28, 2026

By Avery Davis, WB4RTP



What is Field Day

- ▶ It's a contest!!
 - ▶ *Not Really, but it is*
- ▶ It's a social event!!
- ▶ It's a radio event



Field Day Is FUN!!!

ARRL Field Day 2026: Emergency Preparedness and Community Outreach

When Is Field Day?

June 27-28, 2026

Beginning 1800 UTC (1100 MST) Saturday
Ending 1800 UTC (1100 MST) Sunday

Purpose and Activities

The main purpose of Field Day is to promote emergency preparedness, provide community service, and educate the public about amateur radio. Participants operate from temporary locations, using various HF and VHF/UHF bands, aiming to make as many radio contacts as possible while simulating emergency conditions. Operators set up portable antennas and radios, often in parks or remote areas, to practice operating under non-ideal conditions.

Field Day serves as ham radio's open house. Each June, more than 31,000 hams across North America set up temporary stations to demonstrate the science, skill, and service of amateur radio to communities and the nation. The event has been held annually since 1933 and remains the most popular event in ham radio, combining public service, emergency preparedness, community outreach, and technical skills.

Objective

To contact as many stations as possible on the 160-, 80-, 40-, 20-, 15- and 10-Meter HF bands, as well as all bands 50 MHz and above, and to learn to operate in abnormal situations in less than optimal conditions.

Field Day is open to all amateurs in the areas covered by the ARRL/RAC Field Organizations and countries within IARU Region 2. DX stations residing in other regions may be contacted for credit, but are not eligible to submit entries.

Each claimed contact must include contemporaneous direct initiation by the operator on both sides of the contact. Initiation of a contact may be either locally or by remote. Fully automated contacts are prohibited.

6

What Do We Need?

➤ OPERATORS

- Station Captains
- Bonus Captains
- Set Up Crew
- Radios
- Antennas
- Power
- N1MM Loggers



We need Station Captains

7

What openings can you fill?

Station Captains are responsible for the equipment and operations for their station, plus coordinating with other Station Captains for their band and mode. Some equipment will be available for Station Captain use, let us know what you need.

Task	Leader	Comments
Station Capt 160SSB		
Station Capt 160CW		
Station Capt 80SSB		
Station Capt 80CW		
Station Capt 40SSB	Richard K7NSW	Navajo
Station Capt 40CW		
Station Capt 20SSB	Avery WB4RTP	Maricopa 5
Station Capt 20CW	Jeff AD6T	Maricopa 1
Station Capt 15SSB		
Station Capt 15CW		
Station Capt 10SSB	Krysten KR1SS	Maricopa RV
Station Capt 10CW		
Station Capt Digital	Bob K7DC	Maricopa?
Station Capt V/UHF		
Station Capt GOTA	Joe K3TYE	Maricopa?

What
openings
can you
fill?

We need Bonus Captains

FD Bonus Points	Bonus Captains
7.3.1. 100% Emergency Power 100pts	Avery WB4RTP
7.3.2. Media Publicity 100pts	
7.3.3. Public Location 100pts	Avery WB4RTP
7.3.4. Public Information Table 100pts	
7.3.5. Message Origination to Section Manager 100pts	
7.3.6. Message Handling 10pts ea	
7.3.7. Satellite QSO 100pts	
7.3.8. Alternate Power 100pts	Avery WB4RTP
7.3.9. W1AW Bulletin 100pts	
7.3.10. Educational activity bonus 100pts	Joe K3TYE
7.3.11. Site Visitation by an elected governmental official 100pts	
7.3.12. Site Visitation by a representative of an agency 100pts	
7.3.13. GOTA Bonus (updated 2024) 100pts + 5pts ea X 3	Joe K3TYE
7.3.14. Web submission 50pts	Avery WB4RTP
7.3.15. Field Day Youth Participation 20pts ea max 100pts	Joe K3TYE
7.3.16 Social Media 100pts	
7.3.17 Safety Officer Bonus 100pts	Joe K3TYE
7.3.18 Field Day Responsibilities Bonus (new for 2024) 50pts	

What
openings
can you fill?

We need other leaders and crew

Field Day Organization 2026	
Task	Leader
Co-Chair, Camp Lawton	Avery WB4RTP
Co-Chair, Camp Lawton	Joe K3TYE
Pre-reserve site (early campers)	Joe K3TYE
Set up non-radio related infrastructure (tents, tables, etc.)	Joe K3TYE
Food Service Field Kitchen	Joe K3TYE
Set up FD signs	

Where is Field Day for RST?

10

Scout Camp Lawton on Mt. Bigelow

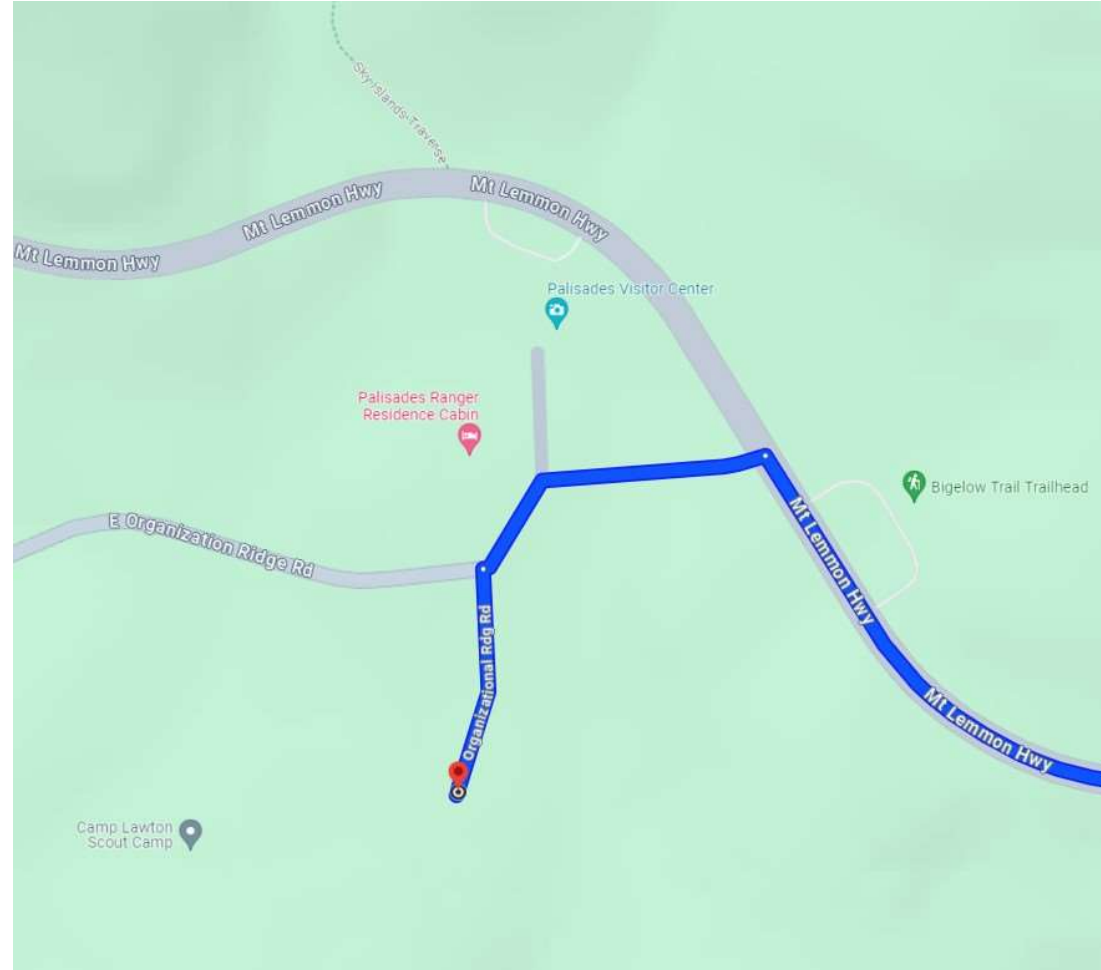
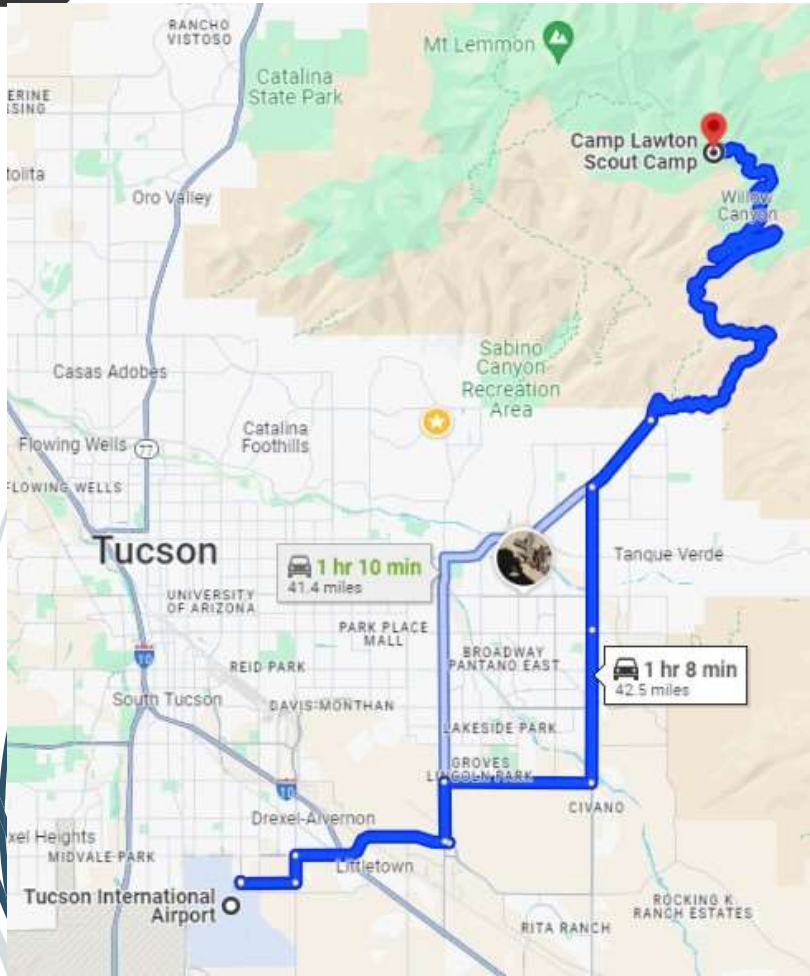

Take the Catalina Highway to Mt Lemmon Highway

11

- ▶ For those of you who use GPS to get you where you're going, the Field Day Site is:
- ▶ Latitude N 32.4084472 degrees
- ▶ Longitude W -110.7163543
- ▶ Address: 12900 E Organization Ridge Rd, Mt Lemmon, AZ 85619
- ▶ <https://catalinacouncil.org/lawton/>
- ▶ 1. Take Catalina Hwy/Mt Lemmon Hwy to E Organization Ridge Rd (just before the Palisade Ranger Station and Visitor Center) and turn left
- ▶ 2. Approximately 1/10 mile bear left through the narrow gates
- ▶ 3. Back-in parking for quick evacuation in case of fire



Scout Camp Lawton Map

12

- Our main area will be the Maricopa Cabins (18) on Staff Hill with the cooking ramada (see photo, below).
- We can use one or more cabins for stations, or tents/canopies at (18).
- Also available is the Navajo Campsite with RV parking at (23).
- Another available site is Oglala Campsite.
- Main Parking (22) is available with RV parking.
- Staff Hill has commercial power; the campsites do not.
- Main parking will be at (22), about 900 feet from Staff Hill (18). Additional parking at (23).

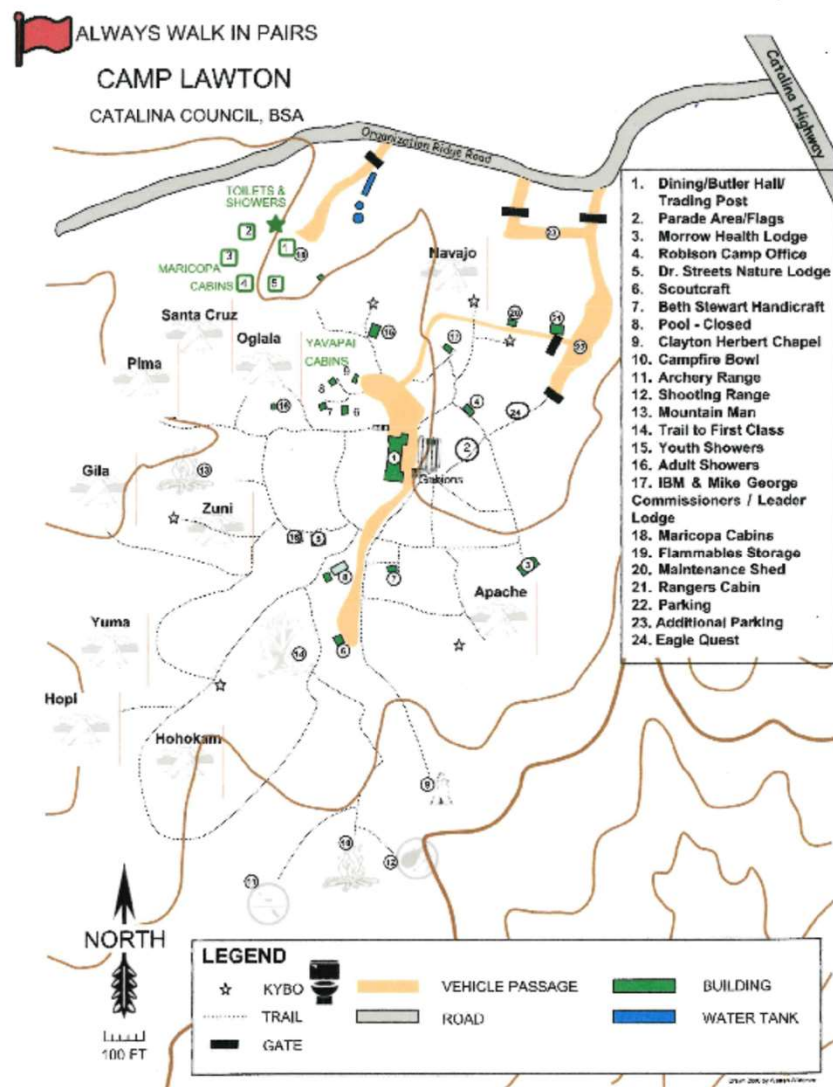

Possible FD station locations

13

- Stations using the same band must be separated by distance to minimize interference.
- One station for each band in Maricopa (18)
- One station for each band in Navajo Campsite & additional parking (23)
- One station for each band at main parking (22)
- Oglala would primarily be used for scout camping.
- Only one station per band and mode may operate simultaneously per ARRL FD rules. Station Captains must coordinate band/mode operations.

CAMP LAWTON CATALINA COUNCIL, BSA

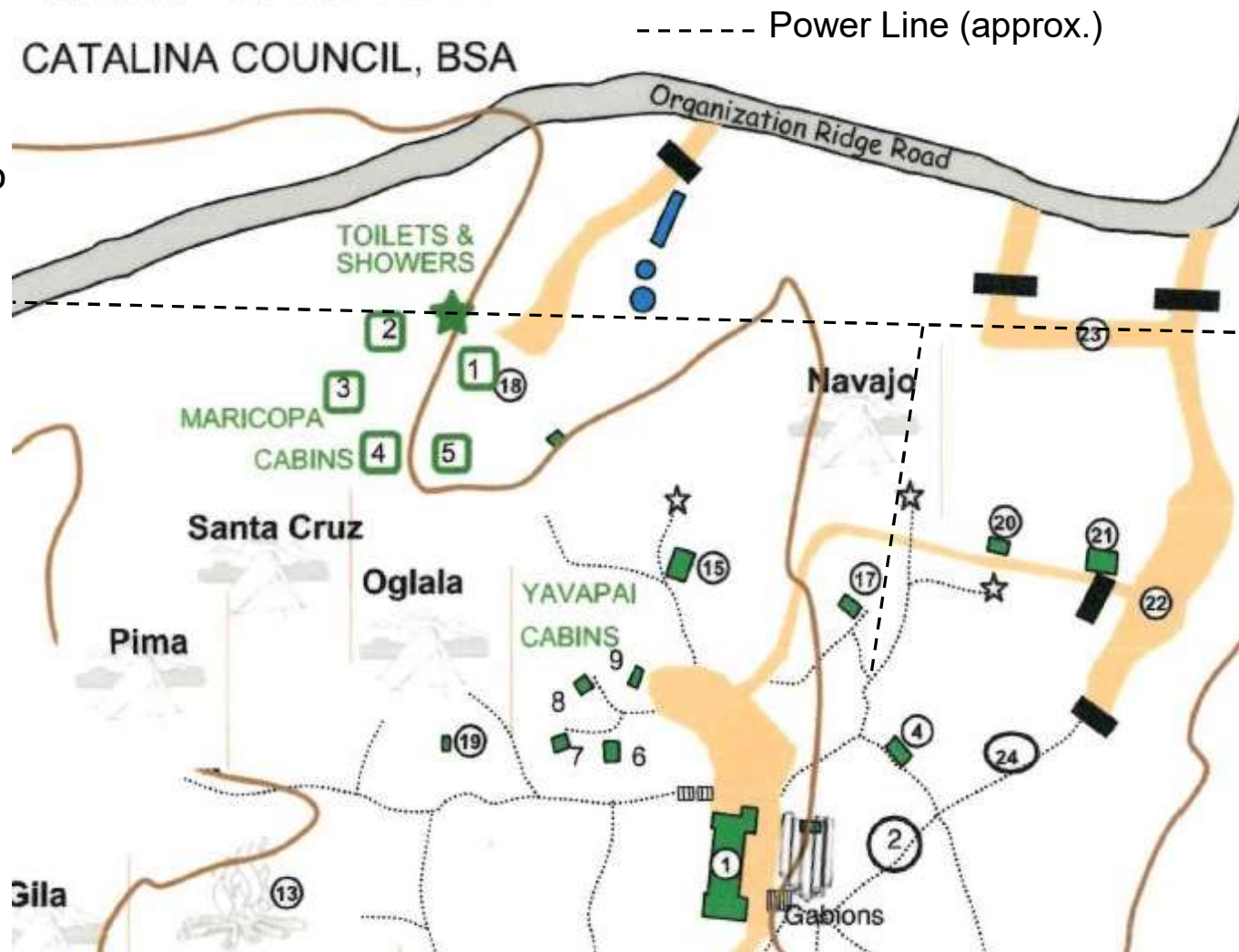

Camp Lawton Power Line Challenge

14

- ▶ A power line cuts across the Northern edge of the camp, so it could be a problem at Maricopa Cabins (Staff Hill) (18), and the additional parking area (23) is right under the power line.
 - ▶ I have been considering running dipoles North-to-South to try to be at right angles to this line in the Staff Hill area.
 - ▶ A spur line runs South over the Navajo camp area, so that would be a problem there.
 - ▶ It looks like the power goes underground before it gets to the dining hall, so stations in that area should be fine, and the South end of the main parking area (22) should be fine.
- ▶ We must expect that we will have to adapt to what we find at Scout Camp Lawton. But hey, having "to learn to operate in abnormal situations in less than optimal conditions" is the objective of Field Day.

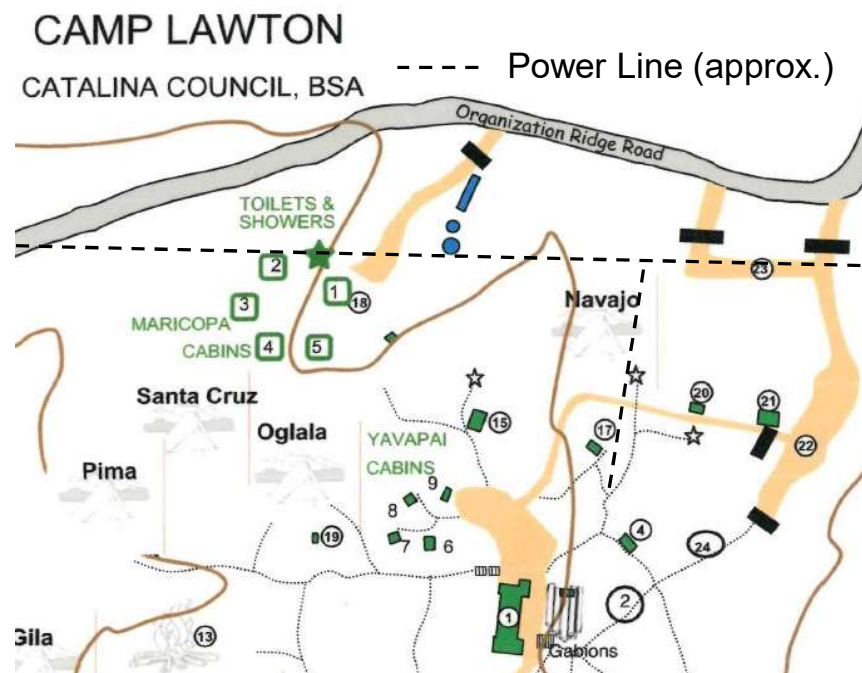

Simplified Schedule

- ▶ Thursday Early Arrival
 - Need reservation with Camp Lawton
- ▶ Friday: some stations captions arrive
 - Start putting up antennas, after 11:00 am MST
- ▶ Field Day Officially Begins 11:00 am on Saturday, 28 June
- ▶ Scouts will prepare meals
 - Dinner Friday, breakfast Saturday & Sunday, Lunch Saturday
 - No Pot Luck dinner
 - You should bring your own food for special dietary requirements
- ▶ Field Day Officially Ends, Sunday, 29 June, 11:00 am MST
- ▶ Pack up everything and decamp early afternoon Sunday

Please be considerate of Scout Camp Lawton Rules

16

- No alcohol or illegal substances
- No smoking, no vaping on the property
- No firearms or other weapons
- Pets are OK if on a leash and are friendly. “[A]ll applicable leash and other laws regarding pets will be adhered to.”
- “T-shirts, caps, or other articles of clothing should not violate the Scout Oath and Law (i.e., depicting alcohol, drugs, tobacco products, or vulgar language are prohibited).”
- Any operator staying over night must have Youth Protection Training (YPT).
- See this web page for details:
<https://campreservation.com/011/Camps/618>

Additional Rules and Considerations

17

All vehicles, campers & RVs **MUST** be backed in for quick evacuation in case of fire!

- Only one RV may be parked at Maricopa Cabins (18)
- RVs are allowed both in the main parking lot (22) and near Navajo (23)
- Pick-up trucks & cars may park at Maricopa (18)
- Limited commercial electricity is available at the Maricopa Cabin (18) parking lot if requested. Let us know if you need a long extension cord.
- All five Maricopa Cabins are available starting on Wednesday evening.
- Non-amateur-radio public will be on site; this will be our opportunity to show off what we are, and what we are doing.

Some meals provided (preliminary menu)

18

- Some meals provided by Scout Troop 157 as a **fund raiser**
 - **When you contribute, you are paying for the food plus a little more to pay for the scout's year-long camping program, so please plan appropriately when contributing for food costs.**
 - Contact Joe, K3TYE, if you plan on partaking so the proper food quantity may be obtained
- Friday Evening Around 6 PM.
 - Subway type sandwiches. Cold drinks to include popular sodas, water, and seltzer. Cake, cookies, or brownies for desert.
- Saturday Breakfast:
 - Ham and scrambled eggs with cheese, plus pancakes. Cold cereal. Maybe some donuts. Coffee, tea, chocolate milk, plain milk, and orange juice.
- Saturday Lunch:
 - Our traditional chicken spiedies, Polish sausage sandwich, or cheeseburgers with chips, potato salad, and baked beans.
- Saturday Supper:
 - Prepared beef taco with chips, and potato salad. Also left overs from lunch.
- Sunday Morning:
 - Ham and scrambled eggs with cheese, plus pancakes. Cold cereal. Maybe some donuts. Coffee, tea, chocolate milk, plain milk, and orange juice.

What To Bring To Field Day

- Bring your own **HEADPHONES** or Headset if you want to operate
- Antenna you want to try
- Radio you want to use
- Friends interested in Ham Radio
- Family
- Food for yourself for special dietary requirements
- Water and beverages
- Camera
- Bug spray
- Sunscreen
- MOST OF ALL JUST AN ENJOYABLE SPIRIT!
 - Its all about having FUN!

Things to do better for Field Day 2026

- ▶ Take more pictures
- ▶ Get everyone to use the same logging software.
- ▶ Designate someone to take a role or make a roster of participants and visitors
- ▶ Get everyone to use Field Day filters
- ▶ Space antennas further apart, especially same band stations
- ▶ Bring your own **HEADPHONES** or Headset if you want to operate
 - ▶ Get everyone to use headphone splitters for logger

Camping

21

- ▶ Camp Lawton has cabins and tent sites
- ▶ Camp Lawton has running water
- ▶ Camp Lawton has commercial power
- ▶ Camp Lawton has trash receptacles
- ▶ No fee for camping
- ▶ Camp Lawton has parking for RVs, but no hookups
- ▶ No Dump Station



- ▶ It's Arizona, but sometimes it really does rain
 - ▶ *Come prepared for the weather*
- ▶ 20-30 degrees cooler than Tucson
- ▶ Sometimes it is actually cold (Yes, it's rare)

Safety

→ Fires

Don't want this....



Safety

23



To Become THIS!!!!

Safety

24

Fires

- Fires are badder than Bears
 - Fire Danger today: Stage 2 Fire Restrictions (5/12/2025)
 - <https://www.fs.usda.gov/r03/coronado/newsroom/releases/fire-activity-and-dry-conditions-prompt-stage-2-fire-restrictions>
 - *No fire (campfire, charcoal, coal, elevated grill, or wood stove)*
 - *No smoking, except within an enclosed vehicle or building.*
 - *No discharging a firearm ... except while engaged in a lawful hunt*
 - *No fireworks, explosives or target shooting.*
 - *No operating any internal combustion engine off designated roadways.*
 - *No welding, or operating an acetylene or other torch with an open flame.*
 - We have had restrictions in prior years

Important Safety Tips

25

► Bears (and other critters)

- *At Camp Lawton there are turkeys, white tail deer, ringtails, squirrels, skunks, and the occasional mountain lion or bear.*
- *In no case should any animal be disturbed in any way.*

► We hang antennas, not people

- *But Exceptions can be made*

- *Beware of low hanging ropes and wires for antennas*

► Watch your step

- *Power Cables on the ground*

- *Antenna coax cables on the ground*

- *Antenna radial and counterpoise wires on the ground*

- *Radials and counterpoises are hot and the courtesy of flagging the ends if they are lying on the ground will be welcome.*

RF Exposure Calculations for FD

26

Power	Mode DC	TX DC	Ant Gain	Freq	Gnd Refl	Controlled Environment		Uncontrolled Environment		Description
						Max PD	Min Safe	Max PD	Min Safe	
Watts	%	TX,RX min	dBi	MHz	y/n	mw/cm2	feet	mw/cm2	feet	
100	50	1,1	2.15	4	y	56.25	0.3999	11.25	0.8941	80m SSB & CW dipole
100	50	1,1	2.15	7	y	18.3673	0.6998	3.6735	1.5647	40m SSB & CW dipole
100	50	1,1	2.15	14	y	4.5918	1.3995	0.9184	3.1294	20m SSB & CW dipole
100	50	1,1	2.15	21	y	2.0408	2.0993	0.4082	4.6941	15m SSB & CW dipole
100	50	1,1	2.15	28	y	1.148	2.799	0.2296	6.2588	10m SSB & CW dipole
100	50	1,1	10	54	y	1	7.4041	0.2	16.556	6m SSB & CW yagi
50	100	1,1	6	146	y	1	4.6716	0.2	10.4461	2m FM 5/8 vertical
50	100	1,1	9	450	y	1.5	5.388	0.3	12.0478	450 MHz FM colinear vertical

From Amateur Radio RF Exposure Calculator at:

<https://www.arrl.org/rf-exposure>

DC is Duty Cycle

TX is transmit, RX is receive

TX DC is TX time and RX time in minutes

PD is Power Density and $1\text{mW}/\text{cm}^2 = 10\text{ W}/\text{m}^2$

Min Safe is minimum safe distance for personnel

Details in backup slides

Emergency Power for Radios for Bonus

27

Normally from gas generators that club provides

- ▶ *These are small generators expecting that stations will have a local battery to provide peak current and backup for when generators need refueling, with a modest 12V power supply to float charge the battery.*
- ▶ *A deep cycle battery would be best. Some prefer LFP (LiFePO₄), but these are expensive.*
- ▶ *Let us know if you need a generator*



Power – IF NO GENERATORS

- Solar
 - *The trees make this difficult*
- Use your car battery or other battery
 - *Run the car when needed to recharge*
 - *Electric Vehicle has a large battery*
 - *If charged on home solar before FD, this does count for the alternate power bonus!*
 - *Use inverters for AC power distribution from batteries*
- Bicycle Generator
- Treadmill
- Other ideas??



Some Equipment Available for Station Captains

29

► Let us know what you need

2026 RST Field Day Equipment List	Model
Equipment Available for FD	
FD bandpass filters: 80m, 40m, 2ea. 20m, 10m	Old style
FD bandpass filters: 2ea 40m, 2ea 20m, 2ea 15m, 1ea 10m	New (ugly) style
40m dipole	
audio stuff (speakers, headphone splitters)	
AC power extention cables, spool	
AC power outlet strips	
Pull cord for antennas, reels	
Coax, on reels, PL-259, 20ft, 50ft, 100ft	RG8x
Generator, 2KW	Honda 2000i
EZflow fuel system for Honda generator	
Jerry can for gasoline & funnel	

Logging Software

- ▶ N1MM has been used very successfully in the past
 - ▶ *Open to suggestions for alternatives*
 - ▶ *Most important thing is for everyone to use the same logging software to make merging logs easier afterwards*

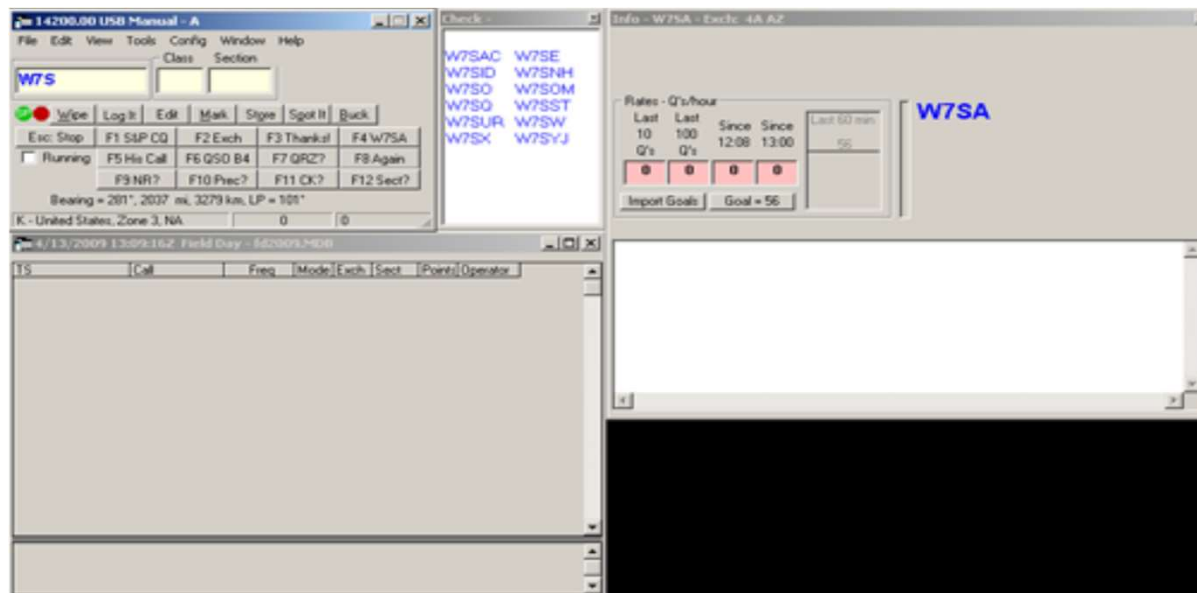

ARRL Field Day Rules (NEED UPDATE)

- ▶ Please review the Official Rules:
 - ▶ <https://www.arrl.org/field-day>
- ▶ **ARRL Field Day rules have not changed from 2025**
- ▶ **New for 2025: 4.1.1 Eligibility Criteria for the GOTA station for class A and F station has changed. GOTA station may operate on any FD band, but only one signal at a time.** GOTA station must use different callsign and must use same exchange.
- ▶ **New for 2024: 7.3.13 GOTA Bonus (Updated for 2024).**
- ▶ **NEW FOR 2023: 4.1.1.5 There is no limit to the number of contacts made by the GOTA station.** QSOs made by this station may be claimed for credit by its primary field day operation. In addition, bonus points may be earned by this station under rule 7.3.13.
- ▶ Entries must be postmarked or submitted by Tuesday, July 29, 2025. Late entries cannot be accepted.

Our FD Operating Class

32

4.1 Class A Portable non-Commercial Power 100W Max

➤ 7.1. QSO Points:

7.1.1. Phone contacts count one point each.

7.1.2. CW contacts count two points each.

7.1.3. Digital contacts count two points each.

➤ 7.2.3 Power multiplier is two (2) at 100W max for non-commercial power but motor-driven generators are allowed

➤ This is what we have done for most Field Days past

Class A Clarification

33

4.1. (Class A) Club / non-club portable: Club or a non-club group of three or more persons set up specifically for Field Day. Such stations must be located in places that are not regular station locations and must not use facilities installed for permanent station use, or use any structure installed permanently for Field Day.

- ▶ Clarification from ARRL on Class A or B:
 - ▶ If a site has several permanent towers or antenna/wire support poles used or unused that can also be used with permission for Field Day, that goes against the purpose of arrive at a site and erect / assemble everything needed for **communications**. You need to come with the mind set that you are going to a known hill or unknown location, setting up [**communications equipment**] from scratch. Wanna use existing [**communications**] features? Set up as Class D, E or F (with EOC permission).
 - ▶ Buildings (shelters/pavilions/gazebos) that pre-exist at a public or private site is **different** -- these are often multi purpose - not just abandoned until a Field Day group shows up to use them once a year. Shelters can be buildings, pavilions, gazebos, tents, campers, RVs, even cabins that were not put there just for the exclusive use of a field day group.

Alternative FD Operating Class

34

▶ Alternate: 4.2 Class A Battery (AB) 5W max

- ▶ 7.2.1 Power multiplier is five (5) for 5W battery on non-commercial mains and no motor-driven generator source allowed
- ▶ An EV charged on solar qualifies as non-com/no-motor source
- ▶ Fewer contacts, but potentially more points
- ▶ Lower power is safer for pacemakers and with lower RF exposure

Operating

- Club Call:
 - K7RST on Mt. Bigelow
 - WN7BSA for GOTA
- Exchange:
 - *Stations in ARRL / RAC sections will exchange their Field Day operating Class and ARRL / RAC section.*
 - *Example: a three transmitter Class A station in Arizona which also has a GOTA station and the extra VHF station:*
 - *Send "3A AZ" on CW or "3 Alpha Alpha Zulu" on Phone.*
- DX stations send operating class and the term DX (i.e. 2A DX).
- Only operate on bands and modes authorized by your station captain!

Example Contact

36

“Running”: Find a clear frequency and call...

- *(us) CQ Field Day (CW: FD), CQ Field Day, this is K7RST, kilo 7 romeo sierra tango*
- *(them) K7RST from N3TN, November 3 tango november*
- *(us) N3TN from K7RST*
- *(them) copy 5 Alpha West PA, 5 Alpha West PA*
- *(us) QSL your 5 Alpha West PA, we are 3 Alpha Arizona, 3 Alpha Alpha Zulu, good luck (CW: GL) in the contest*
- *(another caller may follow immediately, if not call CQ again)*
- Or Hunt and Pounce:
 - Find someone calling CQ field day, such as N3TN
 - Check for duplicate before transmitting!
 - *(us) N3TN from K7RST kilo 7 romeo sierra tango*
 - *(them) K7RST from N3TN*
 - *(us) N3TN copy 3 Alpha Arizona, 3 Alpha Alpha Zulu*
 - *(them) copy 5 Alpha West PA, 5 Alpha West PA*
 - *(us) QSL 5 Alpha West PA, thank you (CW: TU) and good luck (CW: GL) in the contest*
- Ask for clarifications as needed

Please be considerate of each other!

37

It is requested that everyone participating be vaccinated, and to consider wearing masks if feeling ill.

➡ **Let's all try to help each other enjoy Field Day!**

Detailed Schedule

2026 Field Day Planning Schedule			
Date	Time (MST)	Activity	Leader
Tuesday, June 9, 2026	6:30 PM	General meeting, and field day preparation opportunity	Joe K3TYE
Friday, June 12, 2026	9:00 AM	Breakfast Meeting	
Friday, June 26, 2026		Set up FD signs	
Friday, June 26, 2026		Begin setting up non-radio related infrastructure (tents, tables, etc.)	
Saturday, June 27, 2026		Set up food service field kitchen	
Saturday, June 27, 2026	11:00 AM	Station captains should have all station hardware on site and ready to set up	Station captains
Saturday, June 27, 2026	11:00 AM	Antenna and station setup begins. Need crew to help setup!	Station captains
Saturday, June 27, 2026	5:00 PM	Dinner	
Saturday, June 27, 2026	5:00 PM	Copy FD bulletin CW	
Saturday, June 27, 2026	6:45 PM	Copy FD bulletin phone	
Saturday, June 27, 2026	8:00 PM	Copy FD bulletin CW	
Saturday, June 27, 2026	6:00 AM	Breakfast	
Saturday, June 27, 2026	7:00 AM	Copy FD bulletin CW	
Saturday, June 27, 2026	7:30 AM	Copy FD bulletin CW	
Saturday, June 27, 2026	8:00 AM	Copy FD bulletin phone	
Saturday, June 27, 2026	10:00 AM	Functional operations check: Stations (RF), computers and N1MM software	Station captains
Saturday, June 27, 2026	11:00 AM	FIELD DAY OPERATIONS START	Station captains
TBD		Satellite operation demonstration	
Saturday, June 27, 2026	5:00 PM	Dinner	
Saturday, June 27, 2026	11:00 AM	FIELD DAY OPERATIONS END	Station captains
Sunday, June 28, 2026	11:00 AM	Equipment teardown and packing up	Station captains

Current Status of RST Field Day

39

Mountain is currently open

- *But a lot can happen between now and Field Day*
- *Fire danger today: TBD*
 - *No fire (campfire, charcoal, coal, elevated grill, or wood stove)*
 - *No smoking, except within an enclosed vehicle or building.*
 - *No discharging a firearm ... except while engaged in a lawful hunt*
 - *No fireworks, explosives or target shooting.*
 - *No operating any internal combustion engine off designated roadways.*
 - *No welding, or operating an acetylene or other torch with an open flame.*
- *We need rain – Do a rain dance a day!!!*
- *Rain Keeps the Mountain OPEN!!*

Summary

- ▶ Planning for Field Day started in March.
- ▶ Primary plan is to go to Scout Camp Lawton on Mt. Bigelow for Field Day
- ▶ RST Plan B is TBD
- ▶ Field Day this year is 27-28 June 2026

HISTORICAL SLIDES BACKUP SLIDES



2025 CRCRST FD Site Selection

42

Camp Lawton was the winner

Feature or Description	Camp Lawton	Bear Wallow	Radio Ridge	
Site access	Excellent, right behind USFS Palisades Visitor Center	Big rocks limit access	Small parking lots at several sites	
Site reservation	Reserved for us	First come, first serve	First come, first serve	
Site size	Lots and lots of parking	Lots of parking	Good parking at several sites	
Comfort facilities	Running water, flush toilets, showers, commercial power	Dry site, expensive porta potty rental	Dry site, permanent latrine at top site	
Accommodations	Cabins with beds: Maricopa (upper) Cabins on Staff Hill	BYO tents, RVs	BYO tents, RVs	
Cooking	Ramada with electric range & oven + gas grill	BYO grill, tables, canopy, etc.	BYO grill, tables, canopy, etc.	
Forest Service Quiet Time after 10pm	No, we can run generators 24hrs	Yes	Yes	
Cell Service	Very poor	fair	poor	
WiFi	Good	none	none	
Antennas	Lots of trees, but power lines to avoid	Lots of trees	Lots of trees	
High Site	Shadowed by Mt Bigelow to the North	Somewhat shadowed by Mt Bigelow to the East	Somewhat shadowed by Mt Lemmon to the NorthWest	
SCORING				
Green, 2 points each		8	3	2
Yellow, 1 point each		2	1	3
TOTAL		18	7	7

Field Day (Contest) Filters

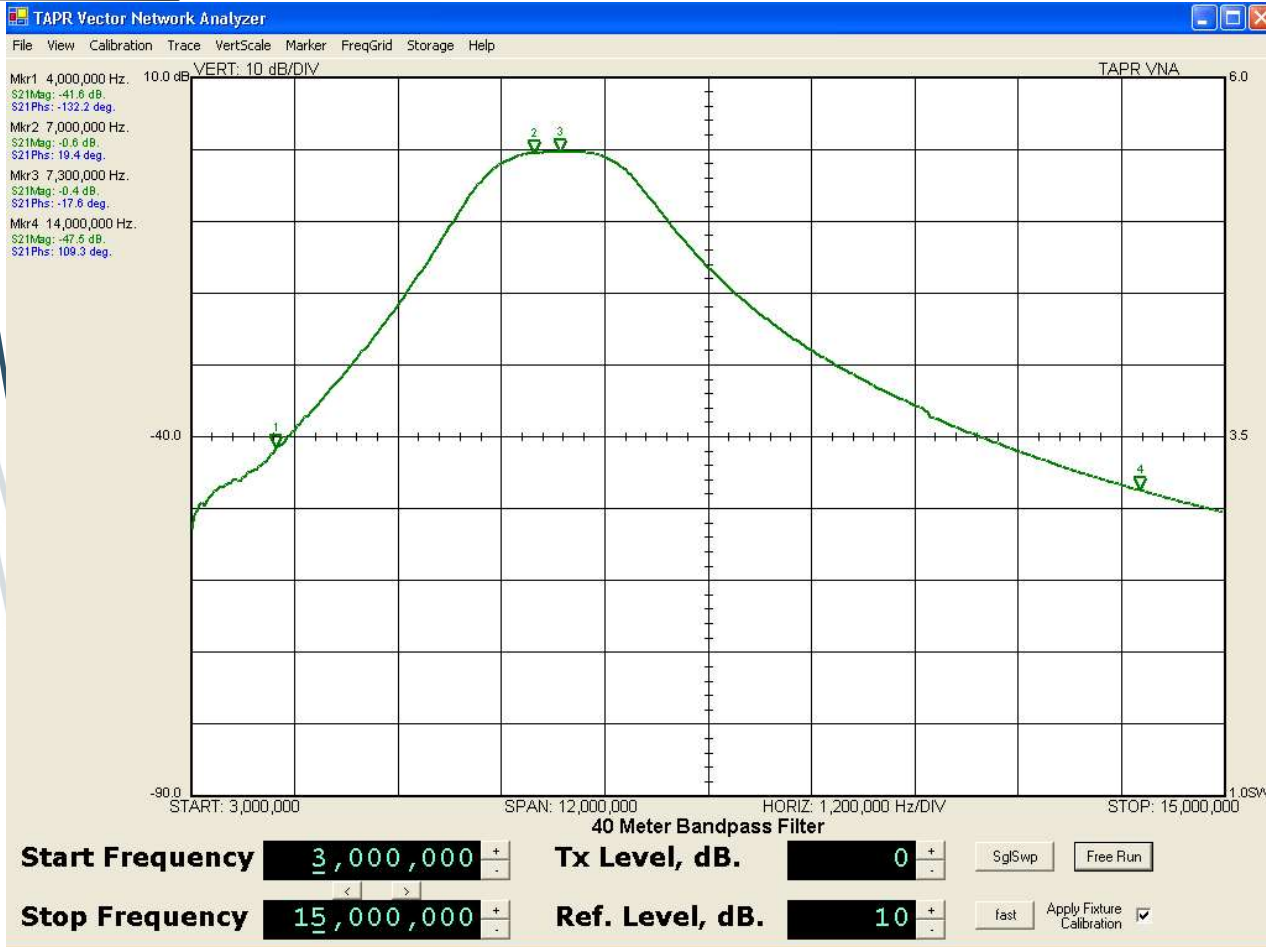

- ▶ Band pass transmitting filter for reducing the interference between HF transceivers operated in close proximity
 - ▶ NVARC “Ugly” Filter
 - ▶ <https://n1nc.org/Filters/>
 - ▶ Easy and inexpensive to build
 - ▶ Great performance
 - ▶ Currently, CRC only has 2: 40m and 20m
 - ▶ WB4RTP brings a second 20m filter
 - ▶ More are being built

Headphone Splitter

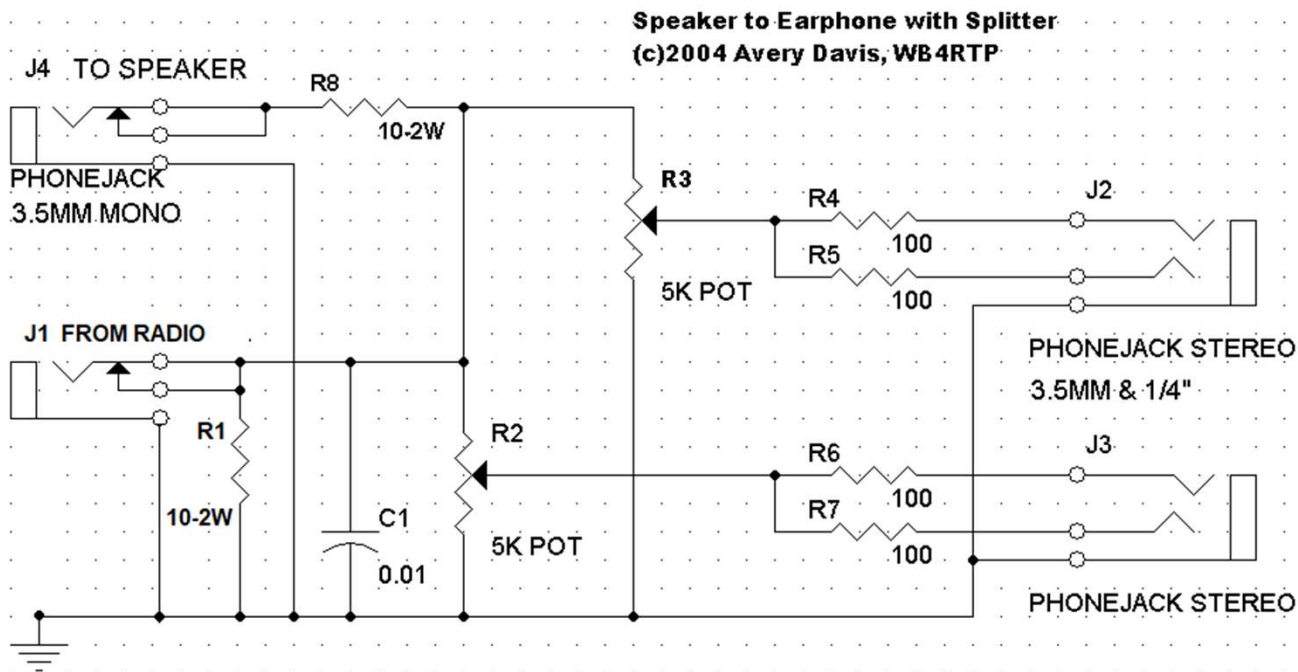

- Allows a second operator/logger to plug in headphones
- Provides separate volume control for both operators
- Splits mono output of radio into both left and right channels
- Has output for lower volume speaker for monitoring by visitors
- Optional: both 3.5mm and 1/4" stereo jacks for headphones

- Currently, CRC has 4 of these
 - WB4RTP has a fifth provided for 20m PH
 - 3 more of these have been built by Lloyd, K7NX

Field Day Calculations: 80m SSB & CW

RF Exposure Calculator

Parameters:

- Power at Antenna: 100 (watts)
- Mode duty cycle: Conversational SSB, heavy speech processing (duty cycle=50%)
 - The calculator lists "Conversationsl CW (duty cycle = 40%)", so using 50% for contest CW is conservative
- Transmit duty cycle: (time transmitting)
- You transmit for 1 minutes then receive for 1 minutes (and repeat).
- Antenna Gain (dBi): 2.15 (dipole)
- Operating Frequency (MHz): 4
- Include Effects of Ground Reflections

Results for a controlled environment:

- Maximum Allowed Power Density (mw/cm²): 56.2500
- Minimum Safe Distance (feet): 0.3999
- Minimum Safe Distance (meters): 0.1219

For an uncontrolled environment:

- Maximum Allowed Power Density (mw/cm²): 11.2500
- Minimum Safe Distance (feet): 0.8941
- Minimum Safe Distance (meters): 0.2725

Field Day Calculations: 40m SSB & CW

RF Exposure Calculator

Parameters:

- Power at Antenna: 100 (watts)
- Mode duty cycle: Conversational SSB, heavy speech processing (duty cycle=50%)
 - The calculator lists "Conversationsl CW (duty cycle = 40%)", so using 50% for contest CW is conservative
- Transmit duty cycle: (time transmitting)
- You transmit for 1 minutes then receive for 1 minutes (and repeat).
- Antenna Gain (dBi): 2.15 (dipole)
- Operating Frequency (MHz): 7
- Include Effects of Ground Reflections

Results for a controlled environment:

- Maximum Allowed Power Density (mw/cm²): 18.3673
- Minimum Safe Distance (feet): 0.6998
- Minimum Safe Distance (meters): 0.2133

For an uncontrolled environment:

- Maximum Allowed Power Density (mw/cm²): 3.6735
- Minimum Safe Distance (feet): 1.5647
- Minimum Safe Distance (meters): 0.4769

Field Day Calculations: 20m SSB & CW

RF Exposure Calculator

Parameters:

- Power at Antenna: 100 (watts)
- Mode duty cycle: Conversational SSB, heavy speech processing (duty cycle=50%)
 - The calculator lists "Conversationsl CW (duty cycle = 40%)", so using 50% for contest CW is conservative
- Transmit duty cycle: (time transmitting)
- You transmit for 1 minutes then receive for 1 minutes (and repeat).
- Antenna Gain (dBi): 2.15 (dipole)
- Operating Frequency (MHz): 14
- Include Effects of Ground Reflections

Results for a controlled environment:

- Maximum Allowed Power Density (mw/cm2): 4.5918
- Minimum Safe Distance (feet): 1.3995
- Minimum Safe Distance (meters): 0.4266

For an uncontrolled environment:

- Maximum Allowed Power Density (mw/cm2): 0.9184
- Minimum Safe Distance (feet): 3.1294
- Minimum Safe Distance (meters): 0.9538

Field Day Calculations: 15m SSB & CW

RF Exposure Calculator

Parameters:

- Power at Antenna: 100 (watts)
- Mode duty cycle: Conversational SSB, heavy speech processing (duty cycle=50%)
 - The calculator lists "Conversationsl CW (duty cycle = 40%)", so using 50% for contest CW is conservative
- Transmit duty cycle: (time transmitting)
- You transmit for 1 minutes then receive for 1 minutes (and repeat).
- Antenna Gain (dBi): 2.15 (dipole)
- Operating Frequency (MHz): 21
- Include Effects of Ground Reflections

Results for a controlled environment:

- Maximum Allowed Power Density (mw/cm²): 2.0408
- Minimum Safe Distance (feet): 2.0993
- Minimum Safe Distance (meters): 0.6399

For an uncontrolled environment:

- Maximum Allowed Power Density (mw/cm²): 0.4082
- Minimum Safe Distance (feet): 4.6941
- Minimum Safe Distance (meters): 1.4308

Field Day Calculations: 10m SSB & CW

RF Exposure Calculator

Parameters:

- Power at Antenna: 100 (watts)
- Mode duty cycle: Conversational SSB, heavy speech processing (duty cycle=50%)
 - The calculator lists "Conversationsl CW (duty cycle = 40%)", so using 50% for contest CW is conservative
- Transmit duty cycle: (time transmitting)
- You transmit for 1 minutes then receive for 1 minutes (and repeat).
- Antenna Gain (dBi): 2.15 (dipole)
- Operating Frequency (MHz): 28
- Include Effects of Ground Reflections

Results for a controlled environment:

- Maximum Allowed Power Density (mw/cm²): 1.1480
- Minimum Safe Distance (feet): 2.7990
- Minimum Safe Distance (meters): 0.8531

For an uncontrolled environment:

- Maximum Allowed Power Density (mw/cm²): 0.2296
- Minimum Safe Distance (feet): 6.2588
- Minimum Safe Distance (meters): 1.9077

Field Day Calculations: 6m SSB & CW

50

RF Exposure Calculator

Parameters:

- Power at Antenna: 100 (watts)
- Mode duty cycle: Conversational SSB, heavy speech processing (duty cycle=50%)
 - The calculator lists "Conversationsl CW (duty cycle = 40%)", so using 50% for contest CW is conservative
- Transmit duty cycle: (time transmitting)
- You transmit for 1 minutes then receive for 1 minutes (and repeat).
- Antenna Gain (dBi): 10 (yagi)
- Operating Frequency (MHz): 54
- Include Effects of Ground Reflections

Results for a controlled environment:

- Maximum Allowed Power Density (mw/cm2): 1.0000
- Minimum Safe Distance (feet): 7.4041
- Minimum Safe Distance (meters): 2.2568

For an uncontrolled environment:

- Maximum Allowed Power Density (mw/cm2): 0.2000
- Minimum Safe Distance (feet): 16.5560
- Minimum Safe Distance (meters): 5.0463

Field Day Calculations: 2m FM

RF Exposure Calculator

Parameters:

- Power at Antenna: 50 (watts)
- Mode duty cycle: FM (duty cycle=100%)
- Transmit duty cycle: (time transmitting)
- You transmit for 1 minutes then receive for 1 minutes (and repeat).
- Antenna Gain (dBi): 6 (5/8 vertical)
- Operating Frequency (MHz): 146
- Include Effects of Ground Reflections

Results for a controlled environment:

- Maximum Allowed Power Density (mw/cm²): 1.0000
- Minimum Safe Distance (feet): 4.6716
- Minimum Safe Distance (meters): 1.4239

For an uncontrolled environment:

- Maximum Allowed Power Density (mw/cm²): 0.2000
- Minimum Safe Distance (feet): 10.4461
- Minimum Safe Distance (meters): 3.1840

Field Day Calculations: 450MHz FM

RF Exposure Calculator

Parameters:

- Power at Antenna: 50 (watts)
- Mode duty cycle: FM (duty cycle=100%)
- Transmit duty cycle: (time transmitting)
- You transmit for 1 minutes then receive for 1 minutes (and repeat).
- Antenna Gain (dBi): 9 (colinear vertical)
- Operating Frequency (MHz): 146
- Include Effects of Ground Reflections

Results for a controlled environment:

- Maximum Allowed Power Density (mw/cm²): 1.5000
- Minimum Safe Distance (feet): 5.3880
- Minimum Safe Distance (meters): 1.6423

For an uncontrolled environment:

- Maximum Allowed Power Density (mw/cm²): 0.3000
- Minimum Safe Distance (feet): 12.0478
- Minimum Safe Distance (meters): 3.6722